



GENERAL FEATURES

- Rack size **45x45 cm**
- Gross weight: 52,5 Kg
- Washing cycles/racks/hour:
- 90°-120°-180°-9' / 40-30-20-7
- Top and bottom wash/rinse arm
- Wash pump: 550 W
- Boiler capacity: 5 liters
- Tank capacity: 18 liters
- Boiler heating element: 2,7 kW
- Tank heating element: 2,4 kW
- Water quantity per cycle: 2 litri
- Electronic controls with LCD display
- Useful washing height: 290 mm
- Magnetic door micro switch
- Automatic water filling
- Double electric detergent and rinse dispenser
- Hot rinse
- Thermostop function
- Anti back-flow valve
- Green Function for energy saving
- Automatic end-of-day self-cleaning water tank
- Washing pump with Soft-Start

FILTRATION

- Plastic wash pump filter, easily removable

BODY

- AISI 304 stainless steel Body
- Partial double skinned body
- Preformed wash tank
- Preformed rack guides
- Double skinned door
- Door handle in s/s
- Wash/rinse arms in s/s, easily removable
- Boiler in s/s AISI 304
- PVC protection rear the bottom front panel

EQUIPMENT

- 1 glass rack 45x45 cm
- 1 plates rack 45x45 cm. 12/14 plates
- 1 cutlery small basket
- 1 inlet hose (length 2 m)
- 1 drain hose (length 2,5 m)

OPTIONAL

- Drain pump
- Cold rinse
- 400V3N~50Hz Version
- 60 Hz version
- Hot water filling
- Kit surface filters
- Kit booster pump
- Kit 4 high feet

ACCESSORIES FOR THE WATER TREATMENT

- Internal water softener ("S" version)

ACCESSORIES

- Special racks

INSTALLATION

- Use the screws of the feet and a spirit level to ensure that the machine is levelled

MAIN POWER SUPPLY

- The voltage of main power supply must be compatible with the rated voltage
- The machine must be connected to a suitable earth (ground) system
- Connect the machine power socket to the multipole wall switch provided

WATER SUPPLY CONNECTION

- A water softener must be installed if the water is hard
- The water pressure must be between 0.2MPa (2 bar), and, 0.5MPa (5 bar)
- The temperature of the water-supply must be between 10°C to 50°C

TECHNICAL SPECIFICATIONS

- Voltage: **220-240V / 380-415 400 V3N~ 50 Hz**
- Total power: **3,25 kW / 5,05 kW**
- Amperage: **14 A / 7 A**
- Power cord supply size :**3x1,5 mmq /5x1,5 mmq**
-

AF 45.30^E

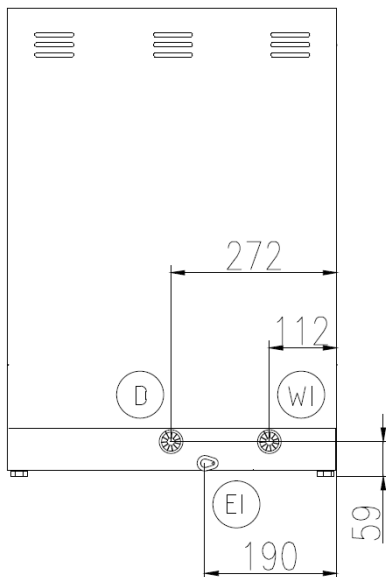
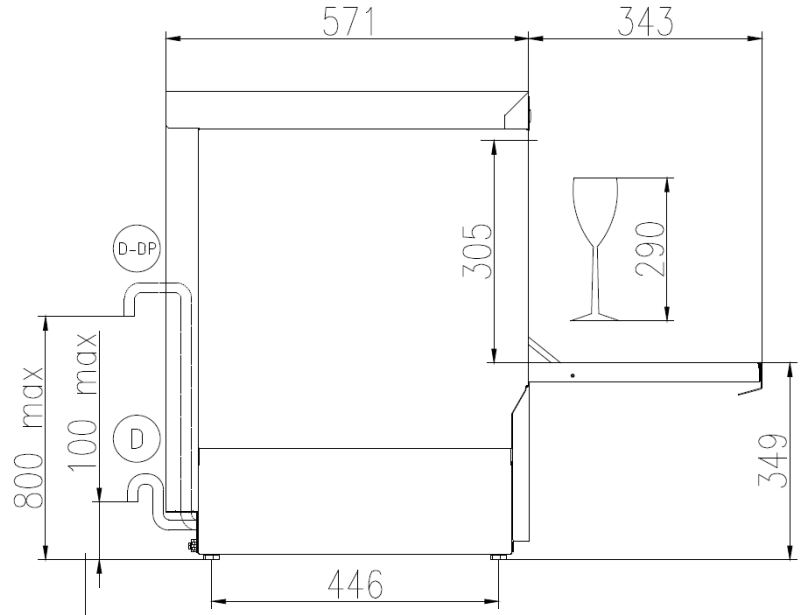
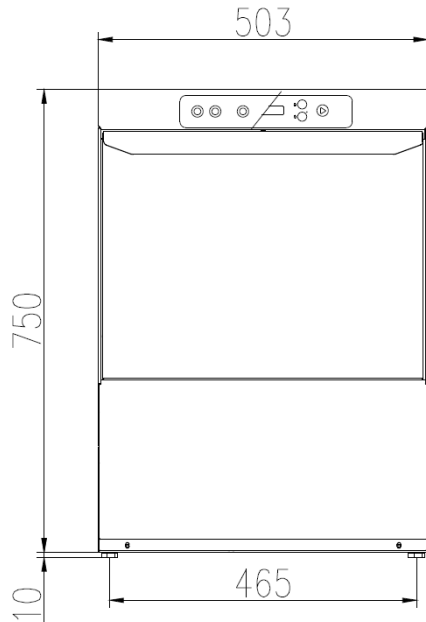

- EI CAVO DI ALIMENTAZIONE
 POWER CORD SUPPLY
 CABLE D'ALIMENTATION
 CABLE DE ALIMENTACION

- WI CANNA DI CARICO G 3/4 L=2000 mm
 G 3/4 INLET HOSE L=2000 mm
 TUYAU D'ALIMENTATION G 3/4" L=2000 mm
 TUBO DE ALIMENTACION G 3/4" L=2000 mm

- D TUBO DI SCARICO ø 29 mm L=2500 mm
 DRAIN HOSE ø 29 mm L=2500 mm
 TUYAU DE VIDANGE ø 29 mm L=2500 mm
 TUBO DE DESAGUE ø 29 mm L=2500 mm

- D-DP TUBO DI SCARICO ø 29 mm L=2500 mm (CON POMPA SCARICO)
 DRAIN HOSE ø 29 mm L=2500 mm (WITH DRAIN PUMP)
 TUYAU DE VIDANGE ø 29 mm L=2500 mm (AVEC POMPE DE VIDANGE)
 TUBO DE DESAGUE ø 29 mm L=2500 mm (CON POMPA DE DESAGUE)

	Min 10°C-MAX 50°C
	Min 10°C-MAX 25°C with ENERGY RECOVERY
	200÷500kPa(2÷5 Bar)
	100÷500kPa(1÷5 Bar) with ATMOSPHERIC BOILER
	HARDNESS 5÷20'f-2.8÷11'd