



GLASSWASHER UX-40

Rack size 400 mm x 400 mm and door clearance 300 mm.



WARE WASHING
COMMERCIAL COMPACT GLASSWASHERS

SALES DESCRIPTION

Sani-Control: guaranteed disinfection
Embedded bodywork and easy-grip door: hygienic and ergonomic
Exclusive Hydroblade™ washing arms: maximum effectiveness.
3-stage filtering system.
Double-walled body (partial).

Sani-Control guarantee

- ✓ GUARANTEED DISINFECTION in compliance with standard DIN 10534.
- ✓ THERMAL LOCK function: Ensures that rinsing will be carried out at the ideal temperature to disinfect the dishes.

New recessed bodywork

- ✓ Ergonomic design with rounded corners to prevent the accumulation of dirt and facilitate cleaning.
- ✓ Compact tank volume (50% water saving compared to the previous range).
- ✓ Embedded basket guides

Hydroblade™ washing arms

- ✓ Redesigned nozzles for greater washing performance.
- ✓ The “monoblock” design delivers durability and resistance to impacts.
- ✓ 30% savings in water consumption during rinsing compared to the previous range.

3-stage filter system: surface, tank and extraction

- ✓ Keeps the washing water in optimal conditions to maintain constant washing performance.
- ✓ The surface filters feature an “easy-on” design and can be quickly removed without having to disconnect the washing arms.

“Easy grip” door: new design with integrated door handle

- ✓ The integration of the components provides greater resistance and robustness.
- ✓ Designed to have no corners or areas that are difficult to access: prevents deposits of dirt and facilitates cleaning.
- ✓ Its ergonomic handle provides a perfect grip, even with wet hands.
- ✓ Double-walled door with safety microswitch and high quality seal
- ✓ 30 cm load capacity: high versatility for washing a wide range of glasses and even medium-sized dishes.

Premium warewashing

- ✓ Ultra Xperience: high performance, without complications.
- ✓ Soft start: progressive start-up of the washing pump to protect fragile items.
- ✓ Colour LCD Display: intuitive communication of the machine status by means of messages, colour codes and icons.
- ✓ Dedicated cycles: selection of the ideal washing programme using icons.
- ✓ Adaptable: allows the main parameters of the machine to be adjusted to the needs of each user.
- ✓ TEMPERATURE DISPLAY
- ✓ Wash Plus+ function: increases the intensity of the wash cycle for greater cleaning performance
- ✓ Control panel with IP65 humidity protection.

You will never WASH ALONE

- ✓ Tech-Services: our team of technicians will help you so that your machine is always ready for use.
- ✓ Design Services: tell us what your needs are and we will advise you.
- ✓ 60 years of experience and know-how at your disposal.

INCLUDES

- ✓ Detergent Dispenser.
- ✓ Rinse aid pump.
- ✓ 1 glasses basket.
- ✓ 1 mixed basket (plates).
- ✓ 1 small basket for cutlery.

OPTIONAL

- Drainage pump with level sensor. Proactive tank water renewal.
- Manual resin regeneration
- water softener.
- Double-level accessory for washing two baskets at the same time.

ACCESSORIES

- Manual water softeners
- Automatic water softeners
- 400 x 400 mm baskets
- Inserts & supplements
- High feet kit
- Reverse osmosis devices OS-140
- Double rack kits for AX/UX

SPECIFICATIONS

Basket dimensions: 400 mm x 400 mm
Useful height: 300 mm
Cycle duration: 90 / 120 / 150 / 180"
Production baskets / hour: 40 / 30 / 24 /

Boiler capacity: 4.5 l
Wash tank capacity: 9 l

Consumption and savings

Water consumption/cycle: 1.9 l
Automatic saving mode in: 25'
Automatic switch-off: 120'

Loading



product sheet
updated 13/02/2024



GLASSWASHER UX-40

Rack size 400 mm x 400 mm and door clearance 300 mm.



- ✓ Pump: 250 W / 0.33 Hp
- ✓ Tank: 1200 W
- ✓ Boiler: 2500 W
- ✓ Total loading: 2750 W

525 x 615 x 820 mm
Gross weight: 44.5 kg

AVAILABLE MODELS

1303102	UX-40 230/50/1 DD
1303107	UX-40B 230/50/1 DD
1303111	UX-40D 230/50/1 DD
1303115	UX-40BD 230/50/1 DD
1303108	UX-40B 220/60/1 DD

* Ask for special versions availability

External dimensions (W x D x H)

- ✓ Width: 470 mm
- ✓ Depth: 540 mm
- ✓ Height: 710 mm

Net weight: 38.5 kg

Noise level (1m.): <69 dB(A)

Crated dimensions

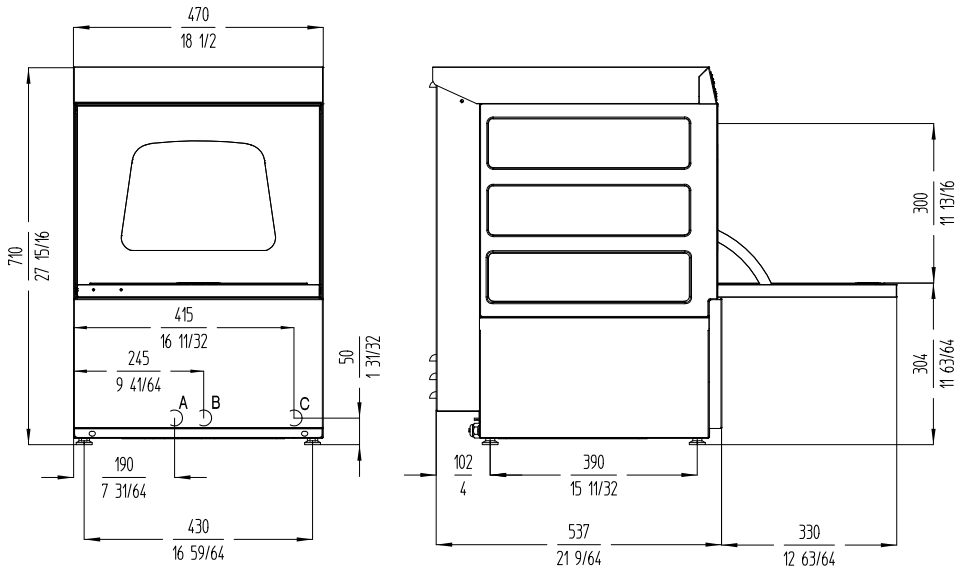

A: Entrada de agua 3/4" GAS.
B: Tubo de desague Ø30 mm.
C: Cable conexión.

WARE WASHING
COMMERCIAL COMPACT GLASSWASHERS



www.sammic.co.uk

Food Service Equipment Manufacturer

Unit 2, Trevanah Road
Troon Industrial Park
LE4 9LS - Leicester

uksales@sammic.com
Tel.: +44 0116 246 1900



Project

Date

Item

Qty

Approved

product sheet
updated 13/02/2024