

CUBETTO PIENO QUADRATO DA EVAPORATORE VERTICALE: Cubetto pieno ad alta densità, di forma quadrata, ottenuto da una lastra di ghiaccio, indicato per raffreddare bevande in situazioni di grande passaggio di clientela, come in fast-food, per grandi eventi.

EVAPORATORE VERTICALE A CASCATA: L'evaporatore verticale è formato da celle cubiche in rame. Una pompa fa cadere l'acqua a cascata dall'alto che penetrando nelle celle si stratifica formando il cubetto. Con l'inversione di ciclo e il passaggio del gas caldo, la lastra che si forma viene staccata dalla griglia e cadendo nel contenitore si spacca in cubetti quadrati. Grande produzione di ghiaccio disponibile in breve tempo e cicli più rapidi, con consumo di acqua ed energia ridotti.

BACK STAGE: Apparecchi modulari da usare in combinazione con uno store (contenitore) di grande capacità da installare generalmente nel retrobottega (backstage): non si fanno vedere ma lavorano sodo producendo ghiaccio in continuazione. Particolarmente indicati per ristoranti, hotels, discoteche, fast-food. Rappresentano un infaticabile produttore che soddisfa anche i picchi di stagione e di lavoro.

SQUARED ICE CUBE: High density squared ice cube, obtained from a single ice plate, perfect for the cooling of drinks in place with big presence of customers like fast foods, big events.

VERTICAL EVAPORATOR MACHINES: The vertical evaporator is composed of a single grid with square copper cells. The pumps allows the water to fall from the upper part, producing a big plate of ice. Thanks to the hot gas, the plate falls down on the store, breaking in small squared ice cubes. Big ice production in short time and faster cycle, for lower water consumption and energy saving.

BACK STAGE: Modular machines to be fitted on a separate storage for big ice capacity, to be usually installed on the backstage: hard workers, continuous production. Really suitable for restaurants, hotels, discos, fast foods. They are a good solution also for the high-season business.

GLAÇON PLEIN CARRÉ PRODUIT PAR ÉVAPORATEUR VERTICAL : Glaçon plein haute densité, de forme carrée, obtenu à partir d'une plaque de glace. Indiqué pour refroidir les boissons dans des situations de fort passage de clientèle, comme dans les fast-foods, les grands événements.

ÉVAPORATEUR VERTICAL EN CASCADE : L'évaporateur vertical est constitué de cellules cubiques en cuivre. Une pompe fait tomber l'eau en cascade du haut qui, en pénétrant dans les cellules, se stratifie en formant le glaçon. Avec l'inversion de cycle et le passage du gaz chaud, la plaque qui se forme se détache de la grille et, en tombant dans la réserve, se casse en glaçons carrés. Grande production de glace disponible rapidement et cycles plus rapides, avec consommation d'eau et d'énergie réduite.

BACK STAGE : Appareils modulaires à utiliser en association avec une réserve d'une grande capacité à installer généralement en arrière-salle (back-stage) : on ne les voit pas, mais ils travaillent dur, en produisant en continu de la glace. Particulièrement indiqués pour restaurants, hôtels, discothèques, fast-foods. Ils sont infatigables et satisfont aussi les pics de saison et de travail.

CUBITO MACIZO CUADRADO DE EVAPORADOR VERTICAL: Cubito macizo de alta densidad, de forma cuadrada, obtenido desde una placa, indicado para enfriar bebidas en situación de gran afluencia de clientela, como por ejemplo Fast-food, ya que pueden cargarse directamente en el vaso del contenedor.

EVAPORADOR VERTICAL EN CASCADA: Evaporador vertical formado por unas celdas de cubitos en cobre. Una bomba hace caer el agua en cascada penetrando en la celdas, donde se estratifica formando el cubito. Con la inversión de ciclo y el paso de gas caliente, la placa que se forma se desprende y al caer en el contenedor se convierte en numerosos cubitos cuadrados. Gran producción de hielo disponible en corto espacio de tiempo, ciclos más rápidos con consumos de agua y energía reducidos.

DETRÁS DEL ESCENARIO: Dispositivos modulares para sus uso en combinación con un contenedor de gran capacidad, por lo general instalados en los office o almacenes. Máquinas que no están a la vista pero trabajan incansablemente produciendo hielo para atender las necesidades más exigentes en cuanto a producción.



6 / 10 / 17 gr SQUARED ICE CUBE
10 gr.= Standard

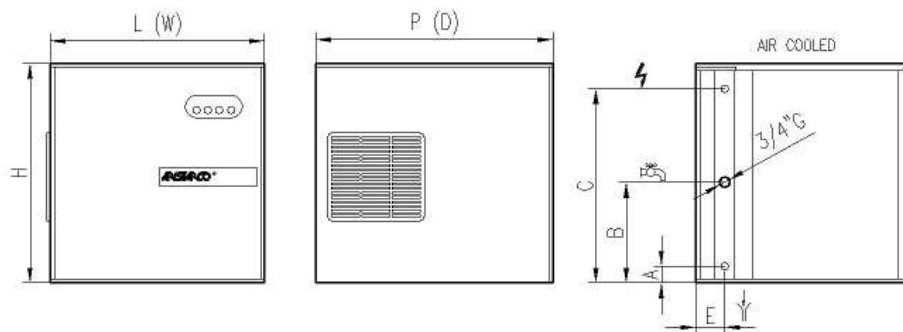

TYPE	A (mm)	B (mm)	C (mm)	E (mm)	F (mm)	G (mm)	M (mm)	L (W) (mm)	P (D) (mm)	H (mm)
KQ 150	43,5	263,5	508,5	75	115	124	352	560	620	575
KQ 250			508,5				351	760		575
KQ 320			508,5				351	760		575
KQ 450			668,5				444	760		725

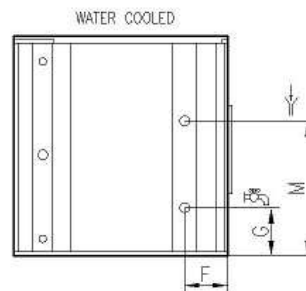

	CQ 150	CQ 250	CQ 320	CQ 400	CQ 450
Sistema di controllo - Control system	E	E	E	E	E
Raffreddamento - Cooling system	A / W	A / W	A / W	A / W	A / W
Produzione in 24h - Production in 24 h (6 gr., or 10 gr., or 17 gr. cubes)	140 kg (cubes no. 23300/14000/8200)	240 kg (cubes no.40000/24000/14100)	300 kg (cubes no.50000/30000/17600)	400 kg (cubes no.66600/40000/23500)	450 kg (cubes no.76000/46000/27000)
Produzione pre ciclo - Production per cycle	275/168/110 ice cubes	370/234/140 ice cubes	370/234/140 ice cubes	555/342/210 ice cubes	555/342/210 ice cubes
Voltaggio standard - Voltage Standard	230 V ~ 50 Hz	230 V ~ 50 Hz	230 V ~ 50 Hz	230 V~ 50 Hz	230 V~ 50 Hz
Potenza assorbita - Power consumption	850 W	1100 W	1400 W	2100 W	2350 W
Tipo di refrigerante - Type of refrigerant	R 452 A	R 452 A	R 452 A	R 452 A	R 452 A
Dimensioni (LxPxH) - Dimensions (WxDxH)	560x620x575 mm	760x620x575 mm	760x620x575 mm	760x620x725 mm	760x620x725 mm
Peso netto - Net Weight	53 kg	68 kg	70,5 kg	88 kg	98 kg
Dimensioni imballo (LxPxH) - Packing dimensions (WxDxH)	630x690x720 mm	830x690x750 mm	830x690x750 mm	830x690x910 mm	830x690x910 mm
Peso lordo - Gross weight	61 kg	81,5 kg	84 kg	106 kg	115 kg

E = Electronic control W = Water cooled A = Air cooled

TEMPERATURA ACQUA
WATER-TEMPERATURE

38°C	70%	65%	60%	55%	50%
32°C	80%	70%	60%	55%	55%
25°C	90%	80%	70%	60%	60%
15°C	100%	100%	80%	70%	65%
10°C	105%	100%	90%	80%	70%
10°C	21°C	32°C	38°C	43°C	

TEMPERATURA AMBIENTE
AMBIENT-TEMPERATURE

ACCESSORI- ACCESSORIES:



Pompa scarico - Drainpump

- Pompa di scarico esterna per fabbricatore di ghiaccio. Portata massima 8 l/min. Altezza massima pompaggio 5 m.
- External drain pump for ice maker. Flow max. 8 l/min. Max fitting height 5 m.



Dosatore di Sali polifasfati

Powder Dosing unit
- Dosatore di Sali polifosfati per prevenire deposito di calcarei.
- Powder Dosing unit to prevent scale built-up.



Acido citrico - Citric

- Acido citrico ad uso alimentare per rimozione calcare.
- Citric acid for food service to remove scale.

SCHEDA TECNICA - TECHNICAL DATA SHEET
MOD. ST S 150 - ST S 200 - ST S 250 - ST S 400

DEPOSITI SERIE ST S

Depositi per ghiaccio, di media capacità, compatibili con vari modelli di fabbricatori di ghiaccio. Indicati per l'utilizzo nei processi industriali alimentari come nell'industria ittica, panificazione e lavorazione delle carni.

CARATTERISTICHE

Isolamento in poliuretano ad alta densità, e deposito interno in polietilene, compatibile con gli alimenti e raggiato per facilità di pulizia. Parte frontale e perimetrale del deposito in acciaio, e, sportello in materiale plastico resistente agli urti. Piedini regolabili 130-185 mm.

ST S SERIES STORAGE BINS

Medium capacity ice storage bins, compatible with many ice machines. Suitable for all the food industries process like in the meat industry, fish markets and bakery.

FEATURES

Polyurethane insulation, high density, and polyethylene bin interior compatible with ice contact, with rounded corners easy to clean. Stainless steel exterior on bin, and robust plastic door with resist operational abuse. Adjustment of feet from 130 mm to 185 mm.

ST S 150

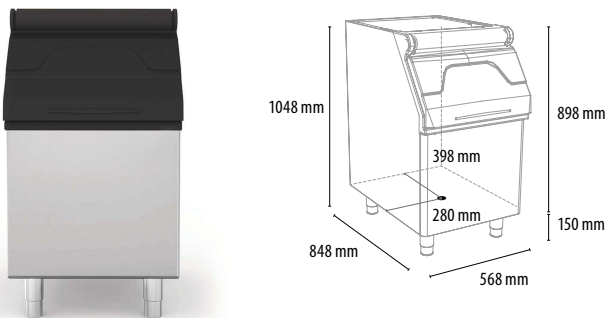

ST S 250

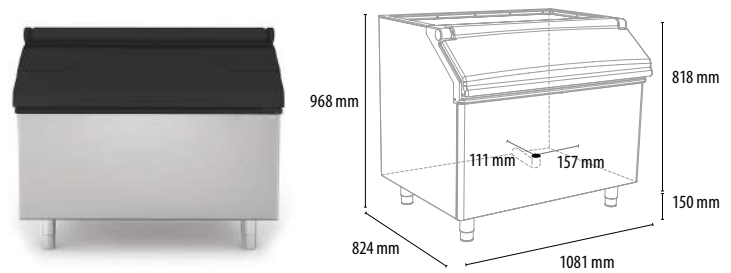

ST S 200

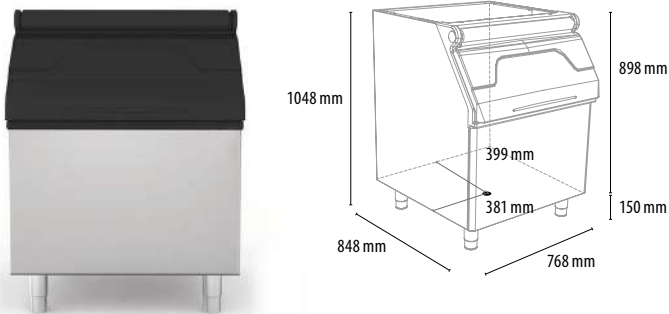

ST S 400

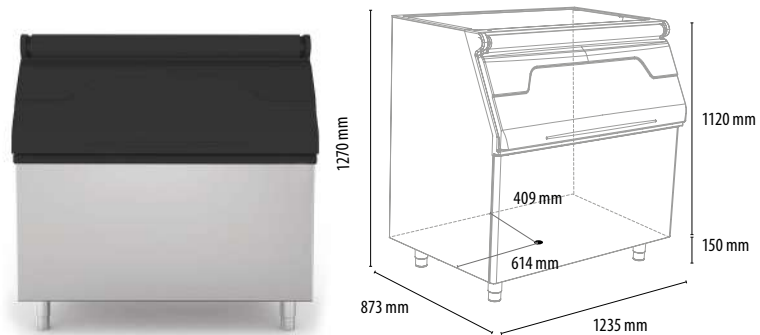

	ST S 150	ST S 200	ST S 250	ST S 400
Dimensioni (LxPxH) - Dimensions (WxDxH)	569x850x1048 mm	769x850x1048 mm	1081x824x968 mm	1235x873x1270 mm
Profondità massima - Maximum depth	1034 mm	1034 mm	944 mm	1155 mm
Capacità deposito - Storage capacity	130 kg	180 kg	250 kg	400 kg
Peso netto - Net Weight	36 kg	43 kg	48 kg	73 kg
Dimensioni imballo (LxPxH) Packaging dimensions (WxDxH)	620x885x1050 mm	822x885x1050 mm	1140x910x960 mm	1300x940x1310 mm
Peso lordo - Gross weight	50 kg	56 kg	63 kg	97 kg

